

FEATURES

- All ceramic epoxy sealed SMD package
- 2 / 4 pads version available
- Small and thinnest package for low frequency
- Low cost option to consumer grade products



Parameters		Specifications
Nominal Frequency Range 標稱頻率範圍	f_0	3.2768MHz ~ 7.0MHz (Fundamental)
Frequency Tolerance, Ta=25°C ± 3°C 常溫頻率偏差	$\Delta f/f$	±20ppm, ±30ppm, ±50ppm
Load Capacitance 負載電容	C_L	18pF or customer specify
Frequency Tolerance over Operating Temperature Range with refer to 25°C 相對於常溫的頻率溫度特性	$\Delta f/f$	±20ppm, ±30ppm, ±50ppm
Operating Temperature Range 工作溫度範圍	T_{OPR}	-20°C ~ +70°C, -40°C ~ +85°C
Storage Temperature Range 儲存溫度範圍	T_{STG}	-55°C ~ +125°C
Drive Level 激勵功率	DL	0.1mW (0.5mW Max.)
Shunt Capacitance 靜態電容	C_0	7pF Max.
Insulation Resistance 絕緣電阻	IR	500MΩ Min.
Aging 老化率	Δf_A	±5ppm/Year Max.

SERIES RESISTANCE (ESR) 串聯諧振阻抗

Frequency Range	3.2768 < f_0 ≤ 7
ESR	120Ω Max.

Please consult our sales representatives for other specifications.
如對其他規格查詢，請與我司銷售人員聯繫

DIMENSION (mm)

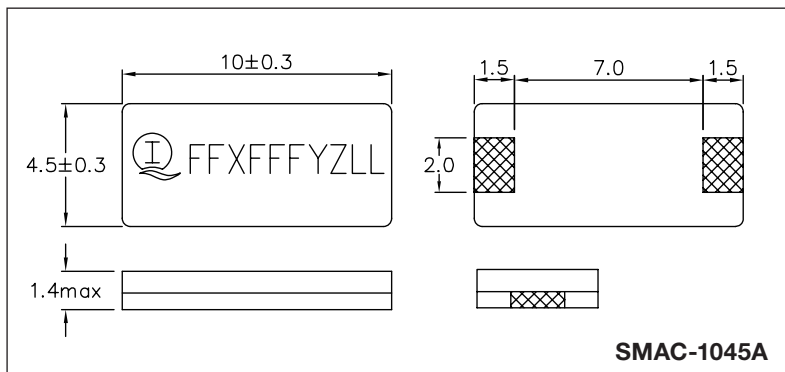

SOLDERING PATTERN (mm)

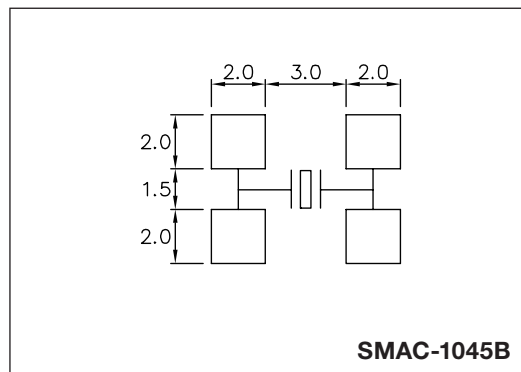
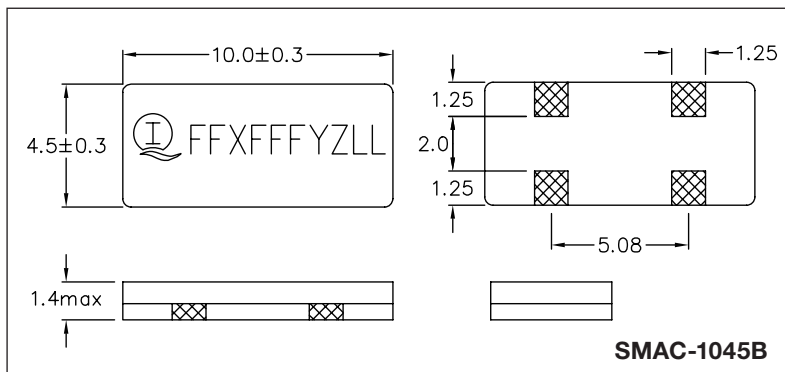
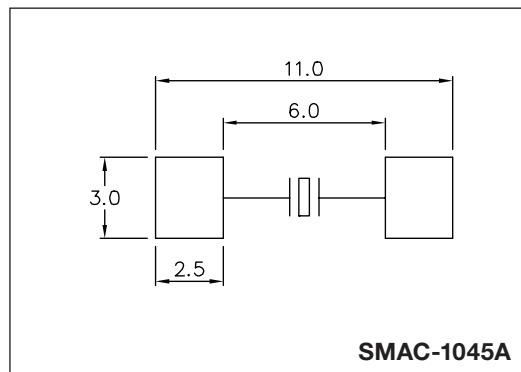

All specifications are subject to change without prior notice.
本公司保留修改規格的權利。

