

- **Tight tolerance and stability, ideal for comms. applications**
- **AT-Cut round crystal blank, optimized for low harmonics**
- **Available up to 200MHz using 5th overtone mode**
- **Annealed and pre-aged for low frequency drift**

DESCRIPTION

U1 and U5 crystals are a well established design, and widely used, particularly in telecommunications applications where their compact size and ability to be produced with close tolerances makes them an ideal crystal. A 'Slimline' package (U1SL) and a surface mount (U1MJ) version is also available.

SPECIFICATION

Frequency Range	U1 and U1MJ	1.0MHz to 1.2MHz (SL-Cut)
	U5 and U5MJ	4.0MHz to 200MHz (AT-Cut)
Oscillation Mode:	See table	
Calibration Tolerance at 25°C	SL-Cut (<1.3MHz):	from ±50ppm
	AT-Cut (>4.0MHz):	from ±3ppm
Frequency Tolerance	SL-Cut:	from ±100ppm -10° to +60°C
	AT-Cut:	from ±3ppm 0° to +50°C
Shunt Capacitance (C0):	4pF typical, 7pF maximum	
Load Capacitance (CL):	Series or from 8pF to 32pF (Customer specified CL)	
Ageing:	±3ppm maximum, 1st year, ±1ppm per year thereafter.	
Drive Level:	100µWatts typ., 500µWatts max.	
Crystal Holder:	Resistance-weld hermetic seal	
Supply format:	Bulk pack	
RoHS Status:	RoHS Compliant and pB free	

FREQUENCY, OSCILLATION MODE, ESR

U1, U1SL and U1MJ

Frequency Range MHz	Crystal Cut/Oscill. Mode	ESR Ω Max.
1.0 ~ 1.2	SL Fund.	5k
6.0 ~ 6.9	AT Fund.	100
7.0 ~ 7.9	AT Fund.	90
8.0 ~ 8.9	AT Fund.	80
9.0 ~ 10.9	AT Fund.	60
11.0 ~ 12.9	AT Fund.	40
13.0 ~ 45.0	AT Fund.	25
30.0 ~ 50.0	AT 3rd o.t.	40
50.1 ~ 100.0	AT 3rd o.t.	50
80.0 ~ 200.0	AT 5th o.t.	80

U5 and U5MJ

Frequency Range MHz	Crystal Cut/Oscill. Mode	ESR Ω Max.
10.0 ~ 11.9	AT Fund.	60
12.0 ~ 14.9	AT Fund.	50
15.0 ~ 35.0	AT Fund.	30
35.1 ~ 90.0	AT 3rd o.t.	60
90.0 ~ 135.0	AT 3rd o.t.	40
90.0 ~ 159.0	AT 5th o.t.	100
160.0 ~ 200.0	AT 5th o.t.	80



OUTLINE & DIMENSIONS



U1, U1SL and U5 Leaded Types

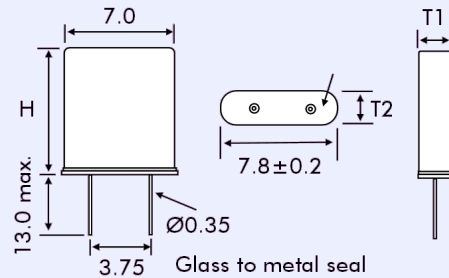

	H	T1	T2
U1	8.0±0.2	2.2±0.2	3.2±0.2
U1SL	8.0±0.2	1.8±0.2	2.6±0.2
U5	6.0±0.2	2.2±0.2	3.2±0.2

U1MJ, U5MJ Metal Jacket SMD Types

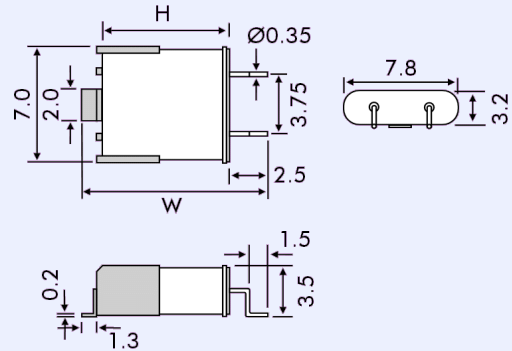

	H	W
U1MJ	8.0±0.2	11.8±0.2
U5MJ	6.0±0.2	9.8±0.2

PART NUMBER FORMAT

Example: **U1 - 8.0000 - 32 -10/10/-20+70/ 80R**

Package
U1, U1SL, U5, U1MJ, U5MJ

Frequency in MHz

Load Capacitance
(Either SR for series or CL in pF)

Calibration tolerance
at 25°C (±ppm)

Temperature Stability
over temp. range (±ppm)

Operating Temp. Range (°C)
(Lower and upper limits)

Equivalent Series Resistance
(Optional - use when special value is required)